



Choose 2 Rent LLC
4290 NW 4th Street, Miami, FL 33126

Phone 1 (800) 622-6484
Fax 1 (800) 622-6484

info@choose2rent.com
www.choose2rent.com

Connect your Equipment

1. Turn on the Samsung LTE Mobile Hotspot



2. Check if your Hotspot connects to the T-Mobile 4G Network

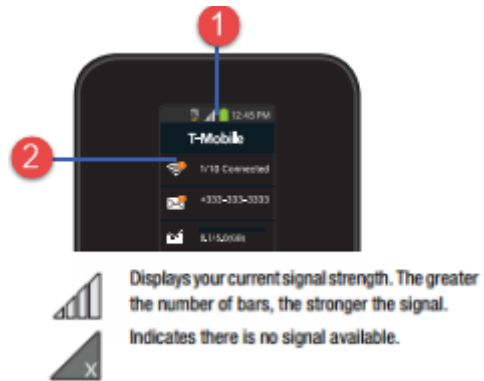

3. Connect the power cord of the Brother QL-710W Printer

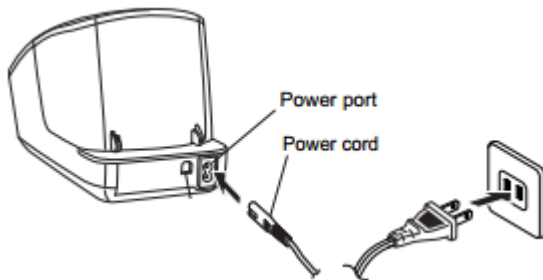

4. Turn on the Brother Printer

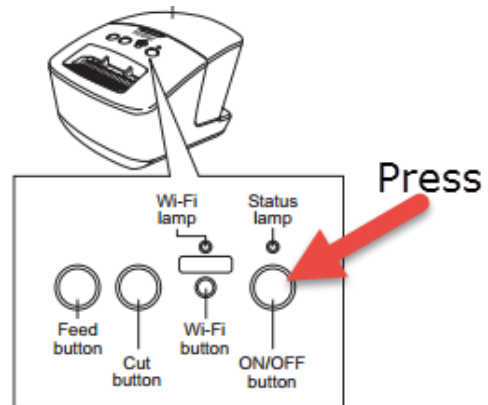

5. The Wi-Fi connection between the Brother Printer and the Hotspot should be established automatically. The following proofs a proper connection:

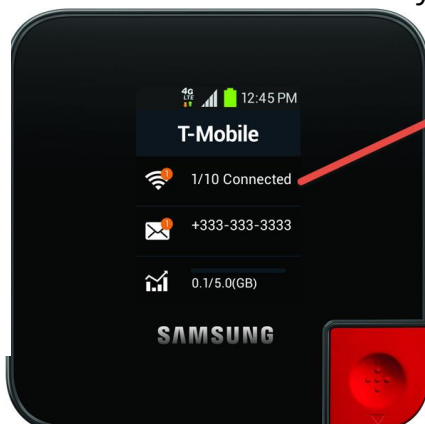

The Hotspot Screen shows:
"1/10 Connected"

The Wi-Fi lamp is **SOLID GREEN**
(no flashing)

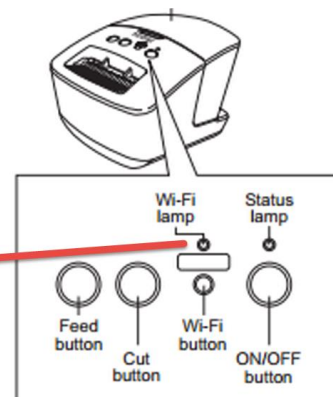

6. Connect the Brother Printer and the Hotspot manually over Wi-Fi
(this applies only if step 5 shows no proper Wi-Fi connection)

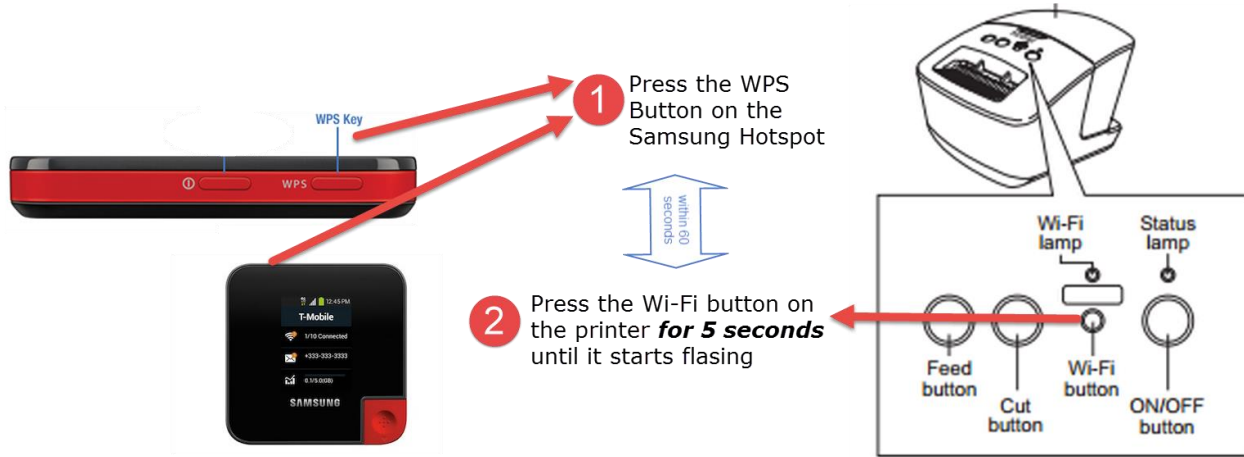

7. Connect your iPads to the Samsung LTE Mobile Hotspot Wi-Fi Network
(Rental iPads are automatically connected)

- On the Hotspot, you will find a label with the network ID and its Password
- Search for the Wi-Fi network on your iPad and connect using the password printed on the label

8. Charging the Samsung LTE Mobile HotSpot PRO

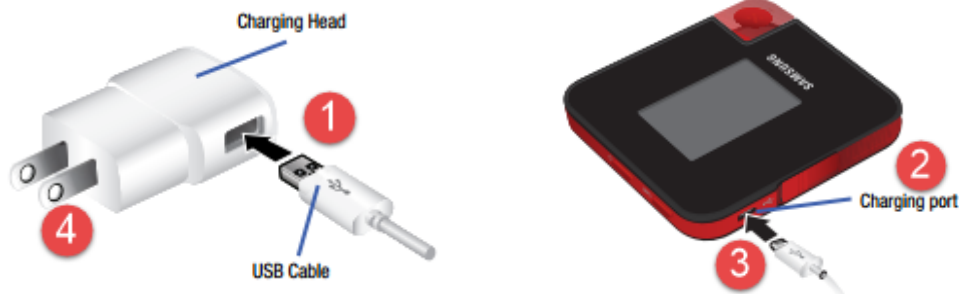

1. Connect the USB cable to the charging head
2. Locate the Charging port
3. Insert the USB cable into the device's Charger/Accessory jack
4. Plug the charging head into a standard AC power outlet

Please call our support team if you need assistance setting up your rental devices - 1(800) 622-6484